

**Leschenko Alexander Petrovich**

**The fundamental structural mechanics of elastic systems: Stability.**

M.: LENAND, 2006. - 216 p.

ISBN 5-9710-0044-6

A. P. Leschenko has offered a completely new approach to structural mechanics, which allowed for a unique technique for structural engineering to be developed. This new method is based on the following three discoveries made by the author:

- Phenomenon of separating torsional strains of elastic bars;
- Specific law of analogy in stability and oscillation of elastic systems;
- Principle of force factors pairing in structural mechanics.

All actual approaches and theories of structural mechanics widely employ such an abstract concept as generalized force, neglecting, however, a definite and practical concept of external force factor. In author's opinion, this breaks the interrelations between the external and internal forces acting on structures and the strains occurring in the structures, which leads to an implicit violation of the classical mechanics laws, namely the law of energy conservation, the Lagrange principle, and Newton's laws. It should be stressed that Leschenko does not suggest that one concept should be simply replaced by the other, but interrelates the external action with other forces and factors concurrently acting on the structure.

Thus, the author has proposed to consider any elastic system as based on three permanently acting factors: 1) external forces; 2) internal forces; and 3) elastic strains; and indicated the principles linking the effects of these factors. Leschenko has developed a graphical scheme (the so-called *triad*) for an analysis of elastic systems. The *triad* analysis of elastic systems has enabled to reveal great contradictions in the available structural calculations of plates, shells and bars. On the other hand, the new method has allowed for an adequate model of stress-and-strain state of constructions to be developed, which, for the first time ever, has made it possible to predict with a high accuracy the moment of structural failure.

As main advantages of the new method we can list comparatively quick calculations of all types of structures, the examination and verification of design solutions, and the detection of critical loads and weak points of constructions. All these result in a considerable saving of materials, which is accompanied by improving the safety of constructions.

The text of this book has been supplied entirely by the author.

Отпечатано в типографии ООО «ЛЕНАНД».  
117312, г. Москва, пр-т 60-летия Октября, д. 11А, стр. 11.  
Подписано к печати 15.11.2005 г. Формат 60x90/16. Печ. л. 13,5. Зак. № 328.

ISBN 5-9710-0044-6

© A. P. Leschenko, 2006

**URSS** Distributor of scientific  
books and university  
textbooks

E-mail: [URSS@URSS.ru](mailto:URSS@URSS.ru)  
Our catalogue on the Internet:  
<http://URSS.ru>  
Phone/fax: 7(095)135-42-16  
Phone/fax: 7(095)135-42-46



URSS

3540 ID 33468



9 785971 000440 >

# Introduction and a brief historical review

---

The second part of the XX century was characterized by the rapid process of scientific/technical revolution which embraced all the spheres of human activity.

The actual task for theory as well as for practice is the scientific understanding and maximum application of scientific/technical achievements born by scientific/technical revolution.

Development of the new branches of engineering as cosmonautics, rocket construction, the study of hydrosphere depth sets the more complicated tasks on calculation of constructions on stability and oscillations before engineers and designers. Accidents and catastrophes of different constructions that still take place in practice testify that the existing methods of calculation of constructions do not take into account all the variety of factors effecting their durability and stability.

In many researches of late the cases of discrepancy between the existing methods of calculation of constructions on stability and practice of designing and experiments were indicated.

The investigators were faced with a need of immediate search of new ways of solving this problem caused by these discrepancies.

To exclude these discrepancies from practice, to explain all the paradoxes in the field of elastic systems' stability, to create a complete theory of constructions' stability — is the main purpose of investigations.

The author has involved to some extent in solving these problems for thin walled constructions.

Over 200 years ago Leonard Euler for the first time considered the problem on buckling of prism bar.

These results have not been used for about one hundred years and only in the second part of the XIX century Euler's research attracted attention.

During this period which was characterized by a rapid growth of industry and construction engineering, the engineering constructions of primary importance which had been built without strict theoretical basis and calculations have appeared. It was the reason of many accidents and catastrophies. Descriptions of some of them already appeared at the end of the XIX century on the pages of technical journals.

V. L. Kirpichev in his book "The course on strength of materials" gives interesting informations that 251 bridges had collapsed in the period from 1875 to

1888 in the USA. Bridges are the most important engineering constructions. All this required development of science of construction mechanics and in particular the part of construction's stability. When accidents of the bridges had been investigated rich material was accumulated which have impulses to development of engineering ideas and construction mechanics.

Thus, after the catastrophe of the bridge across the Kevda river (1875) at Syzran — Morshansk railway F. S. Yassinsky developed the calculation technique of the trusses' compressed belts.

As the result of the analysis of the Tei Bridge wreckage (1879) an effort of wind load at calculation on stability against turning over was taken into account.

After the Quebeck bridge across St. Laurentis river (Canada, 1907) has collapsed, stability of the compressed elements of composed section was considered.

The absence of calculation technique for stability of compressed elements is also the main reason of the bridge wreck across the river Birs at the village of Menhenstein (Switzerland, 1891), the author of which was famous engineer Eifel.

The fields of developing technique as shipbuilding, machine building etc also required strict theoretical grounding. The fact that a field of stability of thin walled constructions and plates had not been studied caused a wreck of the ship "Machchi" at the Spain coast in the seventies of the last century. The elements of the body's covering lost stability at a comparatively small wave and the ship has broken in two. It all happened at the edge of XIX and XX centuries and it pushed forward new problems and profound studies in the field of stability.

Thus, S. P. Timoshenko in 1905 first set the problem on stability of a flat form of i-beam bar.

Russian scientists I. G. Bubnov, S. P. Timoshenko, B. G. Galerkin, P. F. Papkovich, A. N. Krylov, L. S. Leibenson, V. Z. Vlassov and others played the great part in development of theory and calculation technique of constructions.

I. G. Bubnov in his capital paper "Construction mechanics of a ship" solved many particular problems and for the first time completely solved one of the most difficult task — the problem of a plate buckling loaded evenly with distributed load.

In B. G. Galerkin's book "Elastic plates" (1933) the method of a differential equation integration of a plate buckling was proposed.

P. F. Papkovich, the Soviet engineer and the scientist brought invaluable contribution to research in the field of stability of constructions. His eleven theorems on stability of elastic systems are fundamental in this field. Brilliantly combining engineering intuition and analysis of a scientist he stepped far forward. The vast monograph by P. F. Papkovich on building mechanics of a ship is the text book for scientists and engineers.

A merit of the Soviet scientist V. Z. Vlassov should be noted in particular. In 1935 he formulated the law of section areas which he proposed as a basis of practical method of calculation of ribbed arches-shells, general theory of strength and stability of thin walled bars of an open profile.

The author of the present book had to encounter not once with practical aspects of the construction operation.

Thus, analysing the catastrophe at Savinsk concrete plant in Archangelsk region (1970) I established that the designers accepted wrong concepts at calculation of pressed bent elements of columns of raw materials storage. Designed according to generally accepted technique the columns did not endure overloads from the cover of the workshop and became unstable which resulted in the storage collapse. The State suffered great loss. This experiment set by the life made the author to critically observe some aspects of the theory of bars' stability. The analysis of the catastrophe may be seen in Fig. 2.1.

Conclusion: since as at  $e \rightarrow 0$ ,  $N_{pred} \equiv N_3$ , then introducing off-center  $e > 0$  into calculation scheme the conditions of the construction operation get worse and, consequently it should be  $N_{pred} < N_3$ . There is an error admitted in the Inquiry Book [14, p. 246, R. 17.7] as  $N_{pred} > N_3$ .

After the catastrophe the practical question arises: what expenses, time and force will be required to restore the workshop? Simultaneously, an idea occurred: what forces are needed to be applied and what operation they will perform in order to straighten the columns' elements that lost their stability and put them back into the previous position? It appeared that to "uncoil" the columns' twisted elements to the previous position it is necessary to apply a load of a diametrical compression (draft) which could cause a torsion form of stability loss. When the problem was set up the area of elastic and plastic deformations was not limited, but the problem on a load character capable to put the elements into the previous position was set up. In the considered case a load character was of interest but not a fact if this load was real which could take place in practice or unreal, fictitious load. According to loads' classification by P. F. Papkovich, the load of a diametrical compression is a specific one and it corresponds totally to a torsion form of stability loss. Thus, the problem occurred on stability of a diametrically compressed bar.

The further analysis demonstrated that this is a purely bifurcation problem and at certain value, the forces of cross compression may cause purely a torsion form of stability loss the same as according to Euler, the force of central compression may cause a longitudinal curve of a bar.

Revealing of the new type of a load and the search of the ways of its realization in stability problems made the author to turn to the theorems by P. F. Papkovich, to his classification of loads.

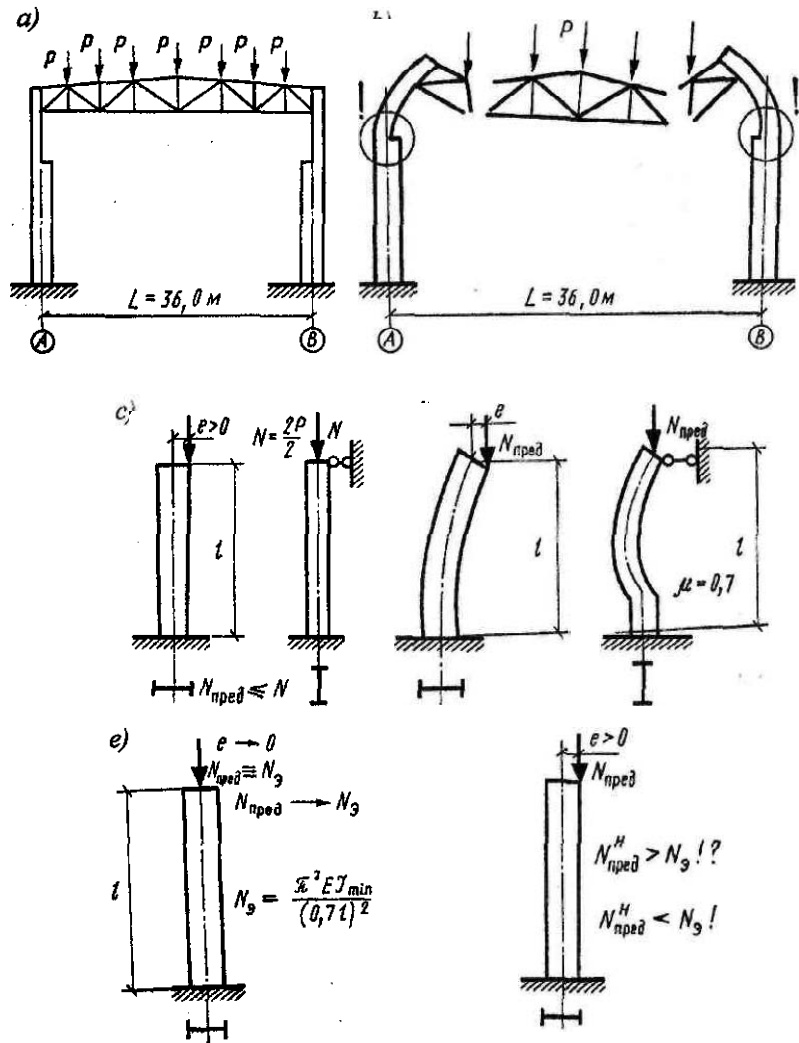

Fig. 0.1. Analysis of the catastrophe in settl. Savinsky, Archangelsk region: a) calculation scheme; b) a scheme of the store house collapse; c) a calculated scheme of a column's element; d) stability loss; e) analysis of the catastrophe.

In development of P. F. Papkovich's ideas and in relation the introduction of new types of load into consideration a more general classification of loads combinations in stability is given in the second chapter of the present book, the

---

concept "analogy" is introduced and a new theorem and a corollary to it are formulated and proved.

For a consistent and argued realization of new concepts it was necessary to carry out the profound analysis of the existing methods of calculation of stability in practice. In the previous book such analysis for thin walled bars is given, contradictions have been revealed in V. Z. Vlassov's theory, the new hypothesis on division of a torsion angle has been proposed and experimental basis of this hypothesis in a theory of stability of thin walled bars has been given.

In order to ground new concepts in the theory of stability a series of experiments on testing eccentrically compressed thin walled bars had been conducted in the laboratories of Leningrad Engineering/Construction Institute which produced positive results and allowed to develop calculation technique of thin walled constructions based on analogy in stability- an analogy method.

Taking part in construction of Kalinin Nuclear Power Plant, the author introduced the analogy method into the practice of construction. Thus, bearing elements of the columns of machinery hall of NPP and the Club of construction workers in t. Udomla, Kalinin region had been recalculated according to the new technique. It produced economical effect of 10 thousand roubles.

A further development of the analogy method allowed to the author to elaborate an oscillation theory and flutter of thin walled constructions.